

# Eureka!

FOR LIFE OUTDOORS.

## ASSEMBLY INSTRUCTIONS FOR THE TIMBERLINE and TIMBERLINE OUTFITTER TENTS:

### Component List:

1 Tent Body,	1 Tent Bag	4 Poles	1 Spanner
1 Tent Fly,	2 Fly Rods	1 Pole Bag	
2 Junction Tubes		1 Stake Bag and Stakes	

- Unroll and unfold the tent and lay it on the ground. Remove the fly and open the tent door. Do not stake down the tent just yet; But in windy conditions, stake down one front corner into wind.

**NOTE:** Do not drop tent bag or pole bag on its end. Do not bounce tent bag on its end to get tent out. These actions may cut the shock cord and/or damage the pole ends.

- Assemble all the shock-corded poles. Make sure each pole section has firmly seated into the adjacent section. Try to keep the poles from snapping together as this can damage the rod ends. Through usage, the aluminum frame may bend slightly and take a "set" this normally does not affect performance.

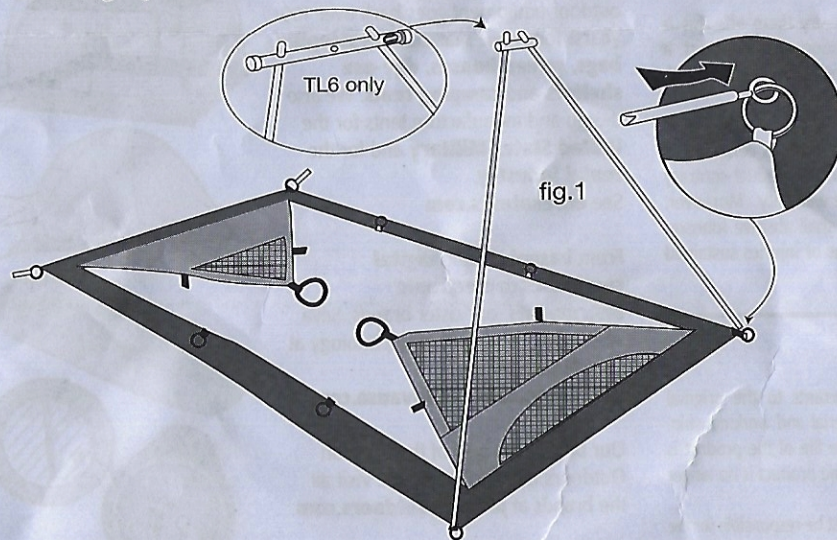

- Place the tapered end of a pole onto the diagonal hole in the junction tube. The junction tube is marked UP RT- [TOP RIGHT on TL6]- so the pole will seat at the correct angle. Insert a corner pin into the other end of the pole. See fig.1.
- Repeat with the second pole and at the back of the tent with the last two poles and the remaining junction tube.

### IMPORTANT:

Do not attempt this assembly with the spanner joined.

- Disconnect the rods in the middle of the spanner. Place one end of the spanner through the center hole of the first junction tube. Place the opposite end of the spanner through the center hole in second tube.

See fig.2.



fig.3

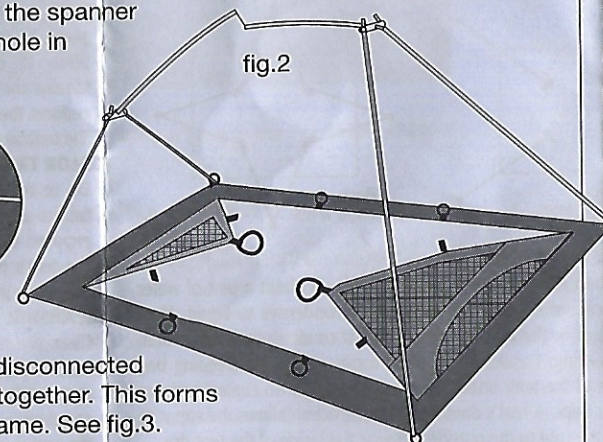

fig.2

- Push down on the disconnected rods until they join together. This forms the free standing frame. See fig.3.

- Connect the tent to frame by pulling the shock-corded loops, at the peaks of the tent, over the junction tubes. Snap tent clips to the poles.

**NOTE:** Junction tubes can be tied to the tent with the strings provided. Tie one end to the shock-cord loop. Pass the other end through the 1/8" hole in the junction tube and tie a knot.

See fig.4.

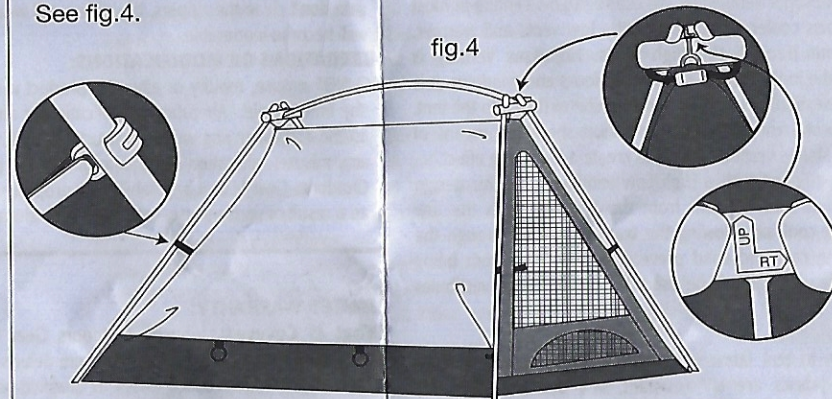
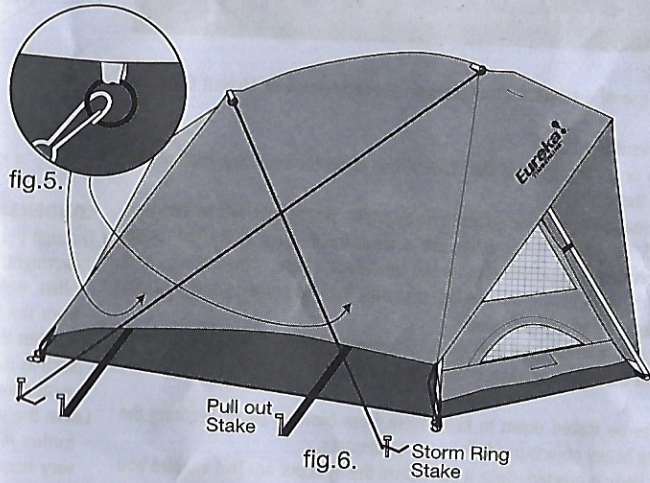

fig.4

- Orient the tent in the desired location and stake it down.
- Fit each of the fly rods over the tip of the spanner section protruding through each junction tube.
- Drape the fly over tent so the center S-hooks [ sewn on the underside of the fly ] line up with the rods.
- Insert the center S-hook into one end of the fly rod. Pull the opposite S-hook and insert it into the end of the second fly rod.



- Connect the snaps on the underside of the fly to the rings on side of the tent. See fig.5.
- Connect four shock-corded S-hooks, located at fly corners, to the ring and pin assemblies at base of each pole.
- Stake down the two pull outs on the sides of the Fly. See fig.6.



### TIMBERLINE SERIES TENTS ARE EQUIPPED WITH HIGH / LOW VENTING DOORS:

- To allow cool air into the tent, unzip the low vent on the door and hold open with the hook and loop tab.
- To vent the fly, unzip the two zippers at the base of the vestibule.
- To allow warm, moist air to escape, unzip the peak of the door and roll down and/or the peak of the back window.

### RECOMMENDATIONS:

- During strong winds, tie extra ropes [ not included ] to the storm rings on the fly and stake down securely. Note staking pattern. See fig.6.

### Take-down task sequence:

- Remove fly and open door.
- Disconnect hooks and peak shock-cords.
- Remove clips from the tent poles; then pull the pins out from the pole ends.

### OPTIONAL EQUIPMENT:

**Annex:** Front awning for storing gear and cooking.

**Gear Loft:** Mesh hammock attaches to rings inside the tent for drying clothes or storing accessories.

**Floor Saver:** Place under tent to protect the floor and keep it clean. Also provides an additional moisture barrier.